





# DeckWise<sup>®</sup>.com

International B.V.



## SMART SOLUTIONS FOR TOUGH DECKS.<sup>™</sup>

-  Des solutions intelligentes pour terrasses durables.
-  Schlaue lösungen für widerstandsfähige terassendielen.
-  Soluciones inteligentes para tarimas resistentes.
-  Slimme oplossingen voor moeilijke dekken.

DeckWise<sup>®</sup> International B.V. Catalog



Please share your project with us!



Partagez vos projets avec nous!



Teilen sie ihr projekt mit uns!



Comparta su proyecto con nosotros!



Deel je project met ons!

[photos@deckwise.com](mailto:photos@deckwise.com)



We love to see DeckWise® products in use, even if it's not a deck - so send us pictures of your decking projects!





Tigerwood decking with Ipe trim installed with DeckWise® Extreme™ and Extreme4™ Hidden deck fasteners. The Hardwood Wrench™ Board Straightener was used to achieve these perfect gap spacing.

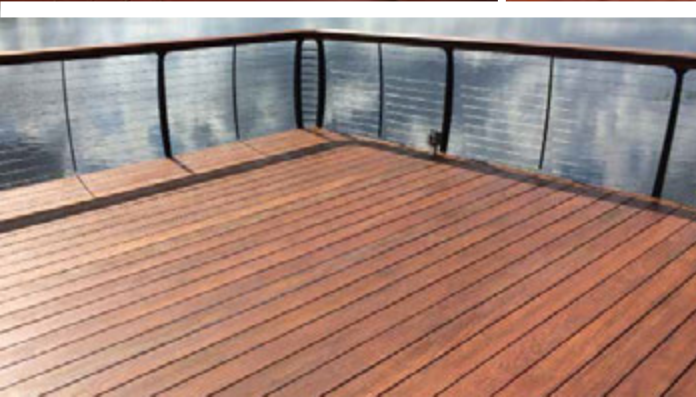
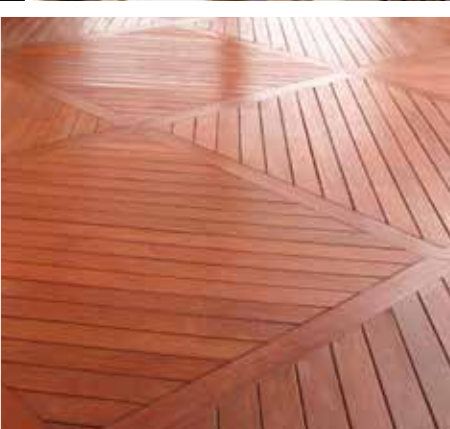
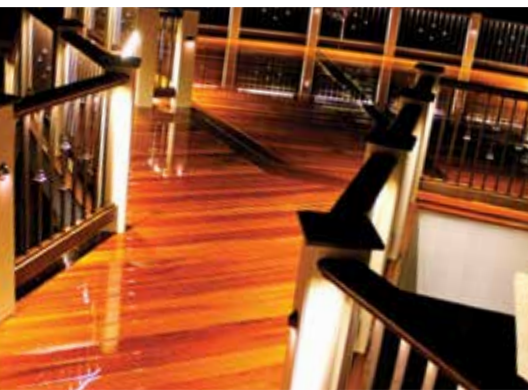



## Manufacturing decking solutions... revolutionizing the decking industry.

Having an in-house team of engineers, designers, machinists, mold makers, & experts in our state-of-the art manufacturing facility gives us the leading edge in creating and designing the best new decking products. We continue testing and improving every product we put our name on. If it is made by DeckWise® - you know you're using the best there is.

Exclusive private co-brand labeling programs are available for dealers & distributors on DeckWise® screws, plugs, spacers, and more! Find out more at +31 33 4691037



**All DeckWise® Hidden Deck Fasteners are proudly engineered and manufactured in our US facility.**





FABRIQUER DE SOLUTIONS DE PLATELAGE

**Toutes fixations invisibles DeckWise® pour platelage sont fièrement conçues et fabriquées dans notre usine aux USA.**



Avoir à disposition une équipe interne d'ingénieurs, de concepteurs, de machinistes, de fabricants de moules et d'experts dans notre installation de fabrication à la pointe de la technologie, nous donne un avantage prépondérant dans la création et la conception des meilleurs produits de platelage. Nous continuons à tester et à améliorer l'ensemble des produits sur lesquels nous apposons notre nom. Si cela est fabriqué par DeckWise®, vous savez que vous utilisez ce qui se fait de mieux.

Des programmes d'étiquetage privés exclusifs sont disponibles pour les revendeurs et distributeurs pour les vis, bouchons et entretoises DeckWise®. Apprenez-en plus sur +31 33 4691037



FERTIGUNG VON LÖSUNGEN FÜR TERRASSENDIELEN

**Alle DeckWise® unsichtbare befestigung werden in unserem werk in den USA hergestellt.**



Unser firmeneigenes team an technikern, designern, maschinisten, formenbauer und fachkräften in unserer hochmodernen produktionsanlage verleiht uns einen vorschub bei der entwicklung und konstruktion der besten neuen produkte für terrassendiele. Wir testen und verbessern andauernd jedes produkt, das unseren namen trägt. Wenn es von DeckWise® hergestellt wurde haben sie die sicherheit, die besten verfügbaren produkte zu verwenden.

Für händler und vertriebshändler gibt es programme für angepasste beschriftung auf den DeckWise® schrauben, stopfen und abstandhalter. Weitere Informationen finden Sie bei +31 33 4691037



FABRICANDO SOLUCIONES

**Todos los sujetadores ocultos de tarima de DeckWise® están orgullosamente diseñados y fabricados en nuestras instalaciones de los Estados Unidos.**



El contar con nuestro propio equipo de ingenieros, diseñadores, mecánicos, matriceros moldistas y expertos en nuestras modernas instalaciones de fabricación nos posiciona como líderes en la creación y el diseño de los mejores y más nuevos productos para el entarimado. Continuamos poniendo a prueba y mejorando cada producto al que le ponemos nuestra firma. Si está hecho por DeckWise®, usted sabe que cuenta con lo mejor disponible.

Exclusivos programas privados de etiquetado están disponibles para proveedores & distribuidores de tornillos, enchufes y separadores de DeckWise®. Encuentre más en +31 33 4691037



WE PRODUCEREN OPLOSSINGEN VOOR VLOERAFWERKING

**Alle onzichtbare DeckWise® dek bevestigingsmiddelen zijn op indrukwekkende wijze ontwikkeld en geproduceerd in onze fabriek in de USA.**



Ons eigen team van ingenieurs, ontwerpers, machinisten, malmakers en deskundigen in onze hypermoderne fabriek geeft ons een competitief voordeel bij het maken en ontwerpen van de beste nieuwe dekproducten. We blijven altijd alle producten met onze naam er op testen en verbeteren. Als het gemaakt is door DeckWise® weet u dat het beste gebruikt wat er op de markt is.

Er zijn exclusieve privé label programma's beschikbaar voor dealers en distributeurs bij DeckWise® schroeven, pluggen, en afstandhouders. Kijk voor meer informatie op +31 33 4691037

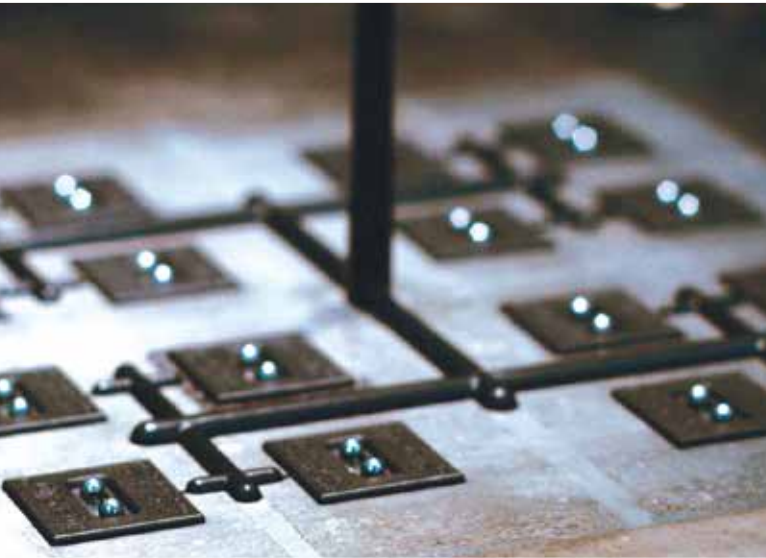

## CONTENTS

### Fasteners

Hidden Deck Fasteners	8
Hidden Cladding Fasteners	10
Stainless Steel Deck Screws	12
Self-Drilling Deck Screws	14
Composite Screws	16
Deck Tile Systems	18
Complete Plug Kit	20
Hardwood Plugs	20
Extreme Plugs <sup>™</sup>	20
Contractor Buckets	30

### Tools

Drill & Drive <sup>™</sup>	22
Hardwood Wrench <sup>™</sup>	24
Board Gap Spacers	26

### Accessories

Drill Bits & Tips	28
-------------------	----

Work Smarter, Not Harder



## SOMMAIRE

### Fixations

Système De Fixations Invisibles	9
Fixations invisibles pour bardage	11
Vis en inox pour platelage	13
Vis auto-foreuses pour terrasses	15
Vis composites	17
Connecteur de dalle de platelage	19
Kits complets de bouchons	21
Extreme Plugs™	21
Seaux pour entrepreneurs	31

### Outils

Drill & Drive™	23
Hardwood Wrench™	25
Entretoises de lattes	27

### Accessoires

Forets et embouts	29
-------------------	----



## INHALTSVERZEICHNIS

### Befestiger

Unsichtbare Befestigung	9
Hartholz-verkleidungen	11
Edelstahlschrauben für terrassendielen	13
Selbstbohrenden schrauben für terassendielen	15
Verbundschrauben	17
Verbinder für holzfliesen	19
Kompletter stopfen-set	21
Extreme Plugs™	21
Eimer für auftragnehmer	31

### Werkzeuge

Drill & Drive™	23
Hardwood Wrench™	25
Abstandshalter	27

### Zubehör

Bohrer und schrauberbits	29
--------------------------	----



## CONTENIDO

### Sujetadores

Sujetadores Ocultos Para Tarima	9
Revestimiento de madera maciza	11
Tornillos de acero inoxidable para la tarima	13
Tornillos autopercutores para tarimas	15
Tornillos compuestos	17
Conector de baldosa de la tarima	19
Kit completo de enchufes	21
Extreme Plugs™	21
Cubetas para contratistas	31

### Herramientas

Drill & Drive™	23
Hardwood Wrench™	25
Separadores de tabla	27

### Accesorios

Brocas & puntas	29
-----------------	----



## INHOUDSOPGAVE

### Bevestigingsmiddelen

Onzichtbare Dek Bevestigingsmiddelen	9
Hardhouten gevelbedekkingsplaten	11
Roestvrij stalen dek schroeven	13
Zelfborende dekschroeven	15
Composietschroeven	17
Dek tegel connector	19
Complete set pluggen	21
Extreme Plugs™	21
Aannemeremmers	31

### Gereedschappen

Drill & Drive™	23
Hardwood Wrench™	25
Plank afstandhouders	27

### Accessoires

Boorkoppen & tips	29
-------------------	----

# HIDDEN DECK FASTENERS



## EXTREME™ Gap spacing 2,38 mm (3/32")



Recommended for use with:  
**Air-Dried Lumber\***



Hardened stainless steel insert  
inside rigid UV-and-chemical-  
resistant polypropylene.

Smaller leg maintains a perfect  
gap when materials contract due  
to environmental conditions.

## EXTREME4™ Gap spacing 4,0 mm (5/32")



Recommended for use with:  
**Kiln-Dried or  
Air-Dried Lumber\***

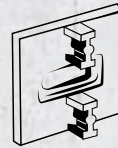

Hardened stainless steel insert  
inside UV-and-chemical- resistant  
polyethylene.

Versatile leg is compatible  
with most decking materials.

## EXTREMEKD™ Gap spacing 6,35 mm (1/4")



Recommended for use with:  
**Kiln-Dried Lumber,  
Composites, PVC\***

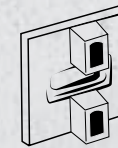

Hardened stainless steel  
insert inside UV-and-chemical-  
resistant polyethylene.

Hollow leg acts as a shock absorber  
as kiln-dried materials expand.

\*Check with decking manufacturer for recommended gap spacing.

Available in our 3 signature colours to match your decking.

These products are protected under one or more of the following patents; D485,160; 8,464,488;  
Other Patents Pending, and/or D470,039 product is licensed under U.S. Patent No. 6,402,415



European kits  
(185 count)

## Complete Kits

- 185 - DeckWise® Hidden Deck Fasteners (175 count in US kits)
- 200 - 50,80 mm (#8x2") Colourmatch Black Stainless Steel Star Drive Screws (190 count in US kits)
- 12 - 9,525 mm (3/8") Tapered Ipe Plugs
- 1 - 3,175 mm (1/8") High Speed Drill Bit
- 1 - Screw Gun Driver Tip
- Instruction Sheet
- Board Spacers included with Extreme4™ and ExtremeKD™ kits





## SYSTÈME DE FIXATIONS INVISIBLES

Ces produits sont protégés par un ou plusieurs des brevets suivants; D485,160; 8,464,488; Autres brevets en instance, et / ou D470,039 produit est distribué sous licence brevet US n° 6,402,415

Disponible dans les 3 couleurs qui font notre signature, afin de s'accorder avec votre platelage.



### EXTREME™

Entretoise d'espacement de 2,38 mm (3/32")

Utilisation recommandée avec: Bois séché à l'air\*

Insert en inox durci dans du polypropylène rigide et résistant aux UV et aux produits chimiques.

Les petites jambes maintiennent un espace parfait lorsque les matériaux se contractent du fait des conditions environnementales.



### EXTREME4™

Entretoise d'espacement de 4,0 mm (5/32")

Utilisation recommandée avec: Bois séché au séchoir, ou séché à l'air\*

Insert en inox durci dans du polypropylène résistant aux UV et aux produits chimiques.

Les jambes polyvalentes sont compatibles avec la plupart des matériaux de platelage.



### EXTREMEKD™

Entretoise d'espacement de 6,35 mm (1/4")

Utilisation recommandée avec: Bois séché au séchoir, Composites, PVC\*

Insert en inox durci dans du polypropylène résistant aux UV et aux produits chimiques.

Les jambes creuses agissent comme un absorbeur de choc alors que les matériaux séchés au séchoir se dilatent.

\*Vérifiez auprès du fabricant du platelage au regard de l'espacement recommandé.

### Kits complets

- 185 - Fixations invisibles DeckWise® pour platelage
- 200 - 50,80 mm (#8x2") Vis à étoile en inox de couleur noire

- 12 - 9,525 mm (3/8") Bouchons coniques d'Ipe
- 1 - 3,175 mm (1/8") Foret haute vitesse de bois
- 1 - Embout de vis pour pistolet à vis

- Mode d'emploi
- Les entretoises sont incluses dans les kits Extreme4™ et ExtremeKD™



## SUJETADORES OCULTOS PARA TARIMA

Estos productos están protegidos bajo una o más de las siguientes patentes; D485,160; 8,464,488; Otras patentes pendientes, y / o D470,039 producto está autorizado bajo la patente de EE.UU. N° 6,402,415

Disponible en nuestros 3 colores emblemáticos para hacer juego con su entarimado.



### EXTREME™

Espaciamento de la separación 2,38 mm (3/32")

Recomendado para el uso con: Madera con secado al aire\*

Inserción de acero inoxidable endurecido y polipropileno resistente a productos químicos y a rayos UV.

Las patas más cortas mantienen una perfecta separación cuando los materiales se contraen debido a condiciones ambientales.



### EXTREME4™

Espaciamento de la separación 4,0 mm (5/32")

Recomendado para el uso con: Madera con secado al horno o madera con secado al aire\*

Acero inoxidable endurecido y polietileno resistente a productos químicos y a rayos UV.

La pata versátil es compatible con la mayoría de materiales de entarimado.



### EXTREMEKD™

Espaciamento de la separación 6,35 mm (1/4")

Recomendado para el uso con: Madera con secado al horno, Compuestos, PVC\*

Inserción de acero inoxidable endurecido y polietileno resistente a productos químicos y a rayos UV.

Las patas huecas actúan como amortiguadores. a medida que los materiales con secado al horno se expanden.

\*Consulte con el fabricante de entarimados para un espaciamento recomendado de las separaciones.

### Kits completos

- 185 - Sujetadores ocultos de tarima DeckWise®
- 200 - 50,80 mm (#8x2") Tornillos de acero inoxidable con cabeza de estrella de la tarima de color negro

- 12 - 9,525 mm (3/8") Enchufes ahusados Ipe
- 1 - 3,175 mm (1/8") Broca de alta velocidad
- 1 - Punta de taladro desentornillador

- Hoja de instrucciones
- Separadores de tabla incluidos con los kits Extreme4™ y ExtremeKD™



## UNSICHTBARE BEFESTIGER FÜR HOLZVERKLEIDUNGEN

Diese Produkte werden unter einem oder mehreren der folgenden Patente geschützt; D485,160; 8,464,488; Andere Patente angemeldet, und / oder D470,039 Produkt unter US-Patent Nr. 6,402,415 lizenziert

Erhältlich in 3 Farben, um zu Ihren terassendielen zu passen.



### EXTREME™

Fugenbreite 2,38 mm (3/32")

Empfohlen für die Verwendung mit: Luftgetrocknetes schnittholz\*

Einsatz aus gehärtetem Edelstahl in robustem UV- und chemikalienbeständigen Polypropylen.

Kleinere Zapfen sorgen für eine perfekte Fuge wenn Materialien sich aufgrund der Umweltbedingungen zusammenziehen.



### EXTREME4™

Fugenbreite 4,0 mm (5/32")

Empfohlen für die Verwendung mit: Künstlich getrocknetes oder luftgetrocknetes schnittholz\*

Einsatz aus gehärtetem Edelstahl in robustem UV- und chemikalienbeständigen Polyethylen.

Die vielseitigen Zapfen eignen sich für die meisten Terrassendielen Materialien.



### EXTREMEKD™

Fugenbreite 6,35 mm (1/4")

Empfohlen für die Verwendung mit: Künstlich getrocknetes schnittholz, Verbundstoffe, PVC\*

Einsatz aus gehärtetem Edelstahl in robustem UV- und chemikalienbeständigen Polypropylen.

Hohle Zapfen fungieren als Stoßdämpfer, wenn sich künstlich getrocknete Materialien ausdehnen.

\*Beim Hersteller der Terrassendielen die empfohlene Fugenbreite einholen.

### Komplettssets

- 185 - DeckWise® Unsichtbare Befestigung
- 200 - 50,80 mm (#8x2") Colormatch schwarz Torx-Edelstahlschrauben

- 12 - 9,525 mm (3/8") Konische Ipe-stopfen
- 1 - 3,175 mm (1/8") Hochgeschwindigkeits-Schrauberbits
- 1 - Schraubereinsatz

- Gebrauchsanweisung
- Abstandhalter inbegriffen bei Extreme4™ und ExtremeKD™ sets



## ONZICHTBARE DEK BEVESTIGINGSMIDDELEN

Deze producten worden beschermd door een of meer van de volgende octrooien; D485,160; 8,464,488; Andere patenten aangevraagd en / of D470,039 product in licentie gegeven onder US Patent No 6,402,415

Beschikbaar in onze 3 sprekende kleuren zodat ze goed bij uw vloerafwerking passen.



### EXTREME™

Tussenruimte 2,38 mm (3/32")

Aanbevolen voor gebruik met: Lucht gedroogd hout\*

Gehard roestvrijstalen inzetstuk in harde, UV- en chemisch bestendige polypropyleen.

Het kleine tussenstukje zorgt voor een perfecte afstand als de materialen krimpen als gevolg van omgevingscondities.



### EXTREME4™

Tussenruimte 4,0 mm (5/32")

Aanbevolen voor gebruik met: Kunstmatig gedroogd hout of lucht gedroogd hout\*

Gehard roestvrijstalen inzetstuk in UV- en chemisch bestendige polypropyleen.

Het veelzijdige tussenstukje is compatibel met de meeste dek materialen.



### EXTREMEKD™

Tussenruimte 6,35 mm (1/4")

Aanbevolen voor gebruik met: Kunstmatig gedroogd hout, Composit, PVC\*

Gehard roestvrijstalen inzetstuk in UV en chemisch bestendige polyethyleen.

Het holle tussenstukje werkt als een schokdemper als het kunstmatig gedroogd materiaal uitzet.

\*Neem contact op met de dek fabrikant voor de aanbevolen afstand.

### Complete Pakketten

- 185 - DeckWise® Onzichtbare dek bevestigingsmiddelen
- 200 - 50,80 mm (#8x2") Bijpassend zwart roestvrijstalen kruiskop schroeven

- 12 - 9,525 mm (3/8") Conische Ipe pluggen
- 1 - 3,175 mm (1/8") Hoge snelheid boorkop
- 1 - Schroefpistool schroefkop

- Instructieblad
- Plank afstandshouders meegeleverd met Extreme4™ en ExtremeKD™ pakketten

# HIDDEN CLADDING FASTENERS



DeckWise® Hidden Cladding Fastener Kit Contains:



DeckWise® Starter Clips



DeckWise® Hidden Cladding Fasteners  
Patent Pending



50,80 mm (#8x2")  
Stainless Steel Trim Head Screws



T15 Driver Tip



Available Kit Options:	50	175	300	1050
	Hidden Cladding Fasteners	Hidden Cladding Fasteners	Hidden Cladding Fasteners	Hidden Cladding Fasteners
	50 - 50,80 mm screws (#8x2")	12 - Starter clips	20 - Starter clips	64 - Starter clips
	1 - T15 Tip	190 - 50,80 mm screws (#8x2")	325 - 50,80 mm screws (#8x2")	1130 - 50,80 mm screws (#8x2")
		1 - T15 Tip	2 - T15 Tips	3 - T15 Tips

Fasten with #8x2" DeckWise® Stainless Steel Screws

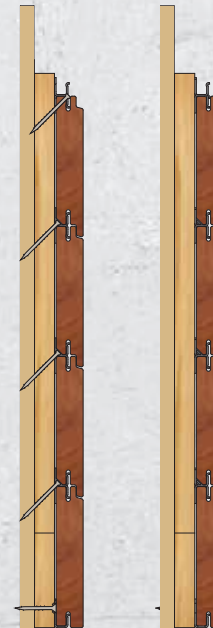
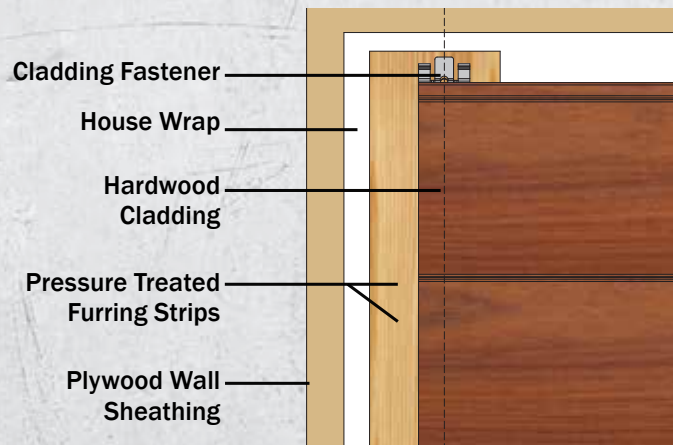

Screws install at a 45° angle for increased holding strength.

Made from high-grade stainless steel for all-weather performance.

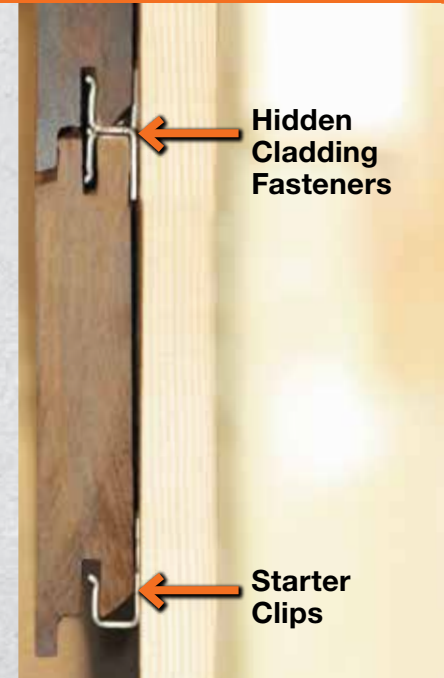



## FIXATIONS INVISIBLES POUR BARDAGE

Fixer avec des vis en inox  
DeckWise® 50,80 mm (#8x2")

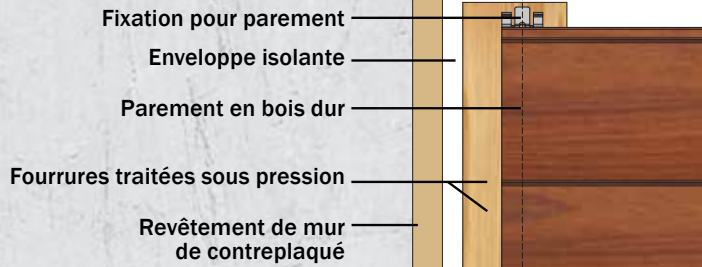

Les vis s'installent à un angle de 45° afin d'augmenter la force de maintien.

Fabriqués en inox de haute qualité pour résister à tous les temps.

### Options de kit disponibles:

#### 50

Système de fixation latéral invisible

50 - Vis de 50,80 mm (#8x2")

1 - Embout T15

#### 175

Système de fixation latéral invisible

12 - Clips de démarrage  
190 - Vis de 50,80 mm (#8x2")

1 - Embout T15

#### 300

Système de fixation latéral invisible

20 - Clips de démarrage  
325 - Vis de 50,80 mm (#8x2")

2 - Embouts T15

#### 1050

Système de fixation latéral invisible

64 - Clips de démarrage  
1130 - Vis de 50,80 mm (#8x2")

3 - Embouts T15



## UNSICHTBARE BEFESTIGER FÜR HOLZVERKLEIDUNGEN

Befestigung mit 50,80 mm (#8x2") DeckWise®  
Edelstahlschrauben

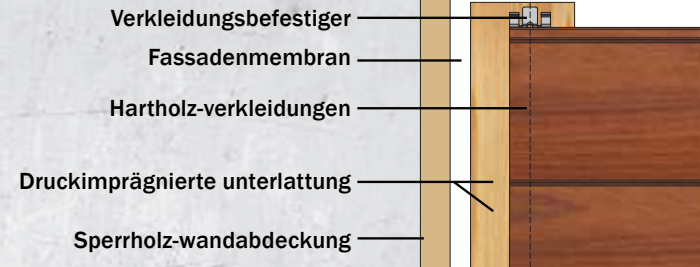

Schrauben werden für höhere Haltekraft in einem 45°-Winkel eingeschraubt.

Aus hochwertigem Edelstahl für alle Witterungsverhältnisse.

### Verfügbare Sets:

#### 50

Unsichtbare befestiger für Holzverkleidungen

50 - 50,80 mm Schrauben (#8x2")

1 - T15 Schraubertit

#### 175

Unsichtbare befestiger für Holzverkleidungen

12 - Starter-clips  
190 - 50,80 mm Schrauben (#8x2")

1 - T15 Schraubertit

#### 300

Unsichtbare befestiger für Holzverkleidungen

20 - Starter-clips  
325 - 50,80 mm Schrauben (#8x2")

2 - T15 Schraubertits

#### 1050

Unsichtbare befestiger für Holzverkleidungen

64 - Starter-clips  
1130 - 50,80 mm Schrauben (#8x2")

3 - T15 Schraubertits



## SUJETADORES OCULTOS DE REVESTIMIENTO

Asegure con tornillos de acero inoxidable  
DeckWise® 50,80 mm (#8x2")

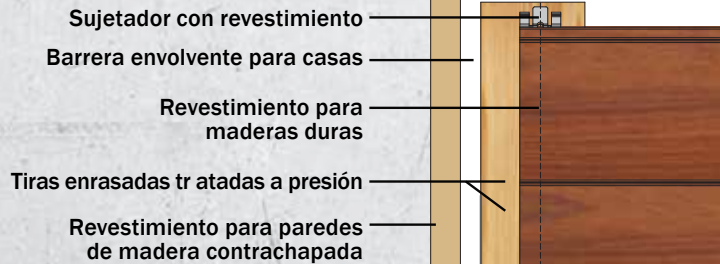

Los tornillos se instalan con un ángulo de 45° para una mayor fuerza de fijación.

Hechos de acero inoxidable de alto nivel para su uso en todo tipo de climas.

### Opciones de kit disponibles:

#### 50

Sujetadores ocultos de revestimiento

50 - Tornillos 50,80 mm (#8x2")

1 - Punta T15

#### 175

Sujetadores ocultos de revestimiento

12 - Clips de inicio  
190 - Tornillos 50,80 mm (#8x2")

1 - Punta T15

#### 300

Sujetadores ocultos de revestimiento

20 - Clips de inicio  
325 - Tornillos 50,80 mm (#8x2")

2 - Puntas T15

#### 1050

Sujetadores ocultos de revestimiento

64 - Clips de inicio  
1130 - Tornillos 50,80 mm (#8x2")

3 - Puntas T15



## ONZICHTBARE GEVELBEPLATING BEVESTIGINGSMIDDELEN

Bevestigen met 50,80 mm (#8x2") DeckWise®  
roestvrijstalen schroeven



Monteer de schroeven onder een hoek van 45° voor een grotere houdkracht.

Vervaardigd van hoogwaardig roestvrij staal voor alle weersomstandigheden.

### Beschikbare Pakket Opties:

#### 50

Onzichtbare bevestigingsmiddelen gevelbeplating

50 - 50,80 mm Schroeven (#8x2")

1 - T15 Boorkop

#### 175

Onzichtbare bevestigingsmiddelen gevelbeplating

12 - Startmotor klemmetjes  
190 - 50,80 mm Schroeven (#8x2")

1 - T15 Boorkop

#### 300

Onzichtbare bevestigingsmiddelen gevelbeplating

20 - Start klemmetjes  
325 - 50,80 mm Schroeven (#8x2")

2 - T15 Boorkoppen

#### 1050

Onzichtbare bevestigingsmiddelen gevelbeplating

64 - Start klemmetjes  
1130 - 50,80 mm Schroeven (#8x2")

3 - T15 Boorkoppen

STAINLESS STEEL  
**COLOUR  
 MATCH**  
 DECK SCREWS

Quantities Available:



SIZES AVAILABLE	38,10 mm (#8x1-1/2")	50,80 mm (#8x2")	63,50 mm (#8x2-1/2")	79,375 mm (#8x3-1/8")
100 COUNT	✓	✓	✓	✓
350 COUNT	✓	✓	✓	✓
1050 COUNT	✓	✓	✓	✓
1750 COUNT	✓	✓	✓	✓

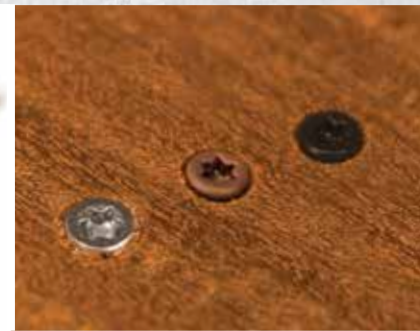

Available in our 3 signature colours, Shadowline Black, Stainless Steel, and Hardwood Brown to match your decking.

**Stainless Steel Deck Screws**

- 305 grade stainless steel for optimum performance with hardwoods
- T15 Star Drive finish heads
- Type 17 auger tips for easy installation

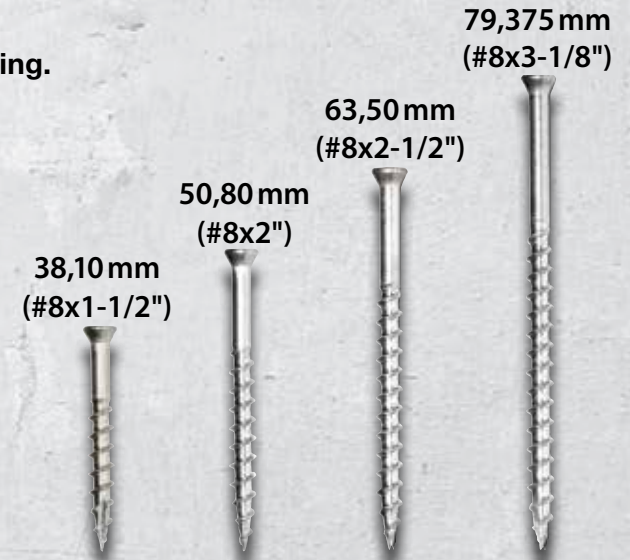



## VIS POUR PLATELAGE EN INOX À TÊTES PEINTES

TAILLES DISPONIBLES	38,10 mm (#8x1-1/2")	50,80 mm (#8x2")	63,50 mm (#8x2-1/2")	79,375 mm (#8x3-1/8")
PAR 100	✓	✓	✓	✓
PAR 350	✓	✓	✓	✓
PAR 1050	✓	✓	✓	✓
PAR 1750	✓	✓	✓	✓

Disponibles en 3 coloris maison, noir shadowline, inox, et marron bois dur pour s'accorder avec vos platelages.

### Vis en inox pour platelage

- Inox de classe 305 pour des performances optimales avec les bois durs
- Embout étoile T15 avec finition
- Embout perçant (Auger) pour installation facile



## EDELSTAHLSCHRAUBEN MIT FARBIGEM KOPF

ERHÄLTICHE GRÖßEN	38,10 mm (#8x1-1/2")	50,80 mm (#8x2")	63,50 mm (#8x2-1/2")	79,375 mm (#8x3-1/8")
100 STÜCK	✓	✓	✓	✓
350 STÜCK	✓	✓	✓	✓
1050 STÜCK	✓	✓	✓	✓
1750 STÜCK	✓	✓	✓	✓

Erhältlich in unseren charakteristischen farben, schattenschwarz, edelstahl und hartholzbraun zur farblichen abstimmung auf Ihre terrassendielen.

### Edelstahlschrauben für terrassendielen

- Edelstahl 305 für optimale leistung bei hartholz
- Köpfe für T15 Torx-schrauberbits
- Schneidespitzen für einfache montage



## TORNILLOS DE ACERO INOXIDABLE CON CABEZA PINTADA PARA TARIMA

TAMAÑOS DISPONIBLES	38,10 mm (#8x1-1/2")	50,80 mm (#8x2")	63,50 mm (#8x2-1/2")	79,375 mm (#8x3-1/8")
100 UNIDADES	✓	✓	✓	✓
350 UNIDADES	✓	✓	✓	✓
1050 UNIDADES	✓	✓	✓	✓
1750 UNIDADES	✓	✓	✓	✓

Disponible en 3 colores distintivos que combinan con su entarimado: negro sombra, acero inoxidable, marrón oscuro de tono madera noble.

### Tornillos de acero inoxidable para la tarima

- Acero inoxidable de 305 grados para un rendimiento óptimo con maderas macizas
- Tornillos con cabeza de estrella T15
- Puntas de taladro para una fácil instalación



## ROESTVRIJ STALEN DEK SCHROEVEN MET GEVERFDE KOP

BESCHIKBARE FORMATEN	38,10 mm (#8x1-1/2")	50,80 mm (#8x2")	63,50 mm (#8x2-1/2")	79,375 mm (#8x3-1/8")
100 STUKS	✓	✓	✓	✓
350 STUKS	✓	✓	✓	✓
1050 STUKS	✓	✓	✓	✓
1750 STUKS	✓	✓	✓	✓

Beschikbaar in onze drie speciale kleuren schaduwlijnzwart, roestvrij staals en hardhoutbruin, net als uw dek.

### Roestvrij stalen dek schroeven

- 305 kwaliteit roestvrij staal voor optimale prestaties met hardhout
- T15 Ster afwerking boorkoppen
- Vijzel tips voor gemakkelijke installatie

# SELF DRILLING DECK SCREWS



## No Pre-drilling Required.

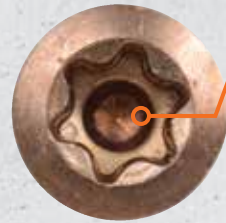

**ttap® T15 Star Drive Head for less slipping.**

**Heat treated for hardened toughness.**

**Serrated saw threads remove sawdust.**

**Four sided tip for self-drilling.**



**DeckWise® Self-Drilling Deck Screws can penetrate hardwoods like Ipe, Cumaru, Tigerwood, Garapa, and Massaranduba.**

**Locking bit to eliminate slipping.**

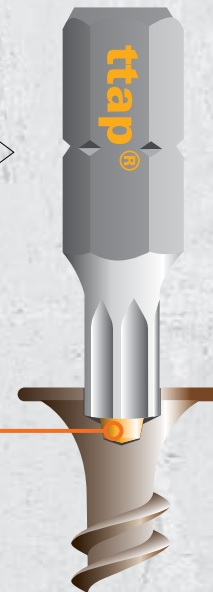

**Ttap®**

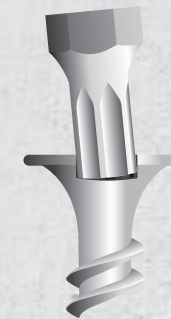

**Cruciform  
(Phillips / Pozidriv)**



**Hexalobular (Torx®)**

\* TTAP® is a registered trademark of TtapDrive AS.



## VIS AUTO-FOREUSES POUR TERRASSES

### Pas besoin de pré-percer.



**ttap**® tête étoile T15 pour obtenir plus d'adhérence.

Traité thermiquement pour obtenir encore plus de solidité.

Le filetage dentelé de la scie permet l'évacuation de la sciure.

Embout à quatre pans permettant l'auto-forage.

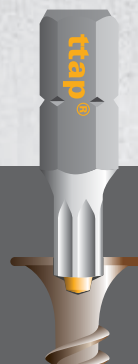

Les vis auto-foreuses pour platelages de DeckWise® peuvent pénétrer dans des bois durs tels que l'Ipé, le Cumaru, le Garapa, le Gonçalo alves et le Massaranduba.



## SELBSTBOHRENDEN SCHRAUBEN FÜR TERRASSENDIELEN

### Kein Vorborenen erforderlich.



**ttap**® mit T15 Torx-schraubenkopf für weniger Rutschen.

Gehärtet für hohe belastbarkeit.

Gezahntes schneidgewinde entfernt sägestaub.

Vierseitige spitze für selbstbohrung.

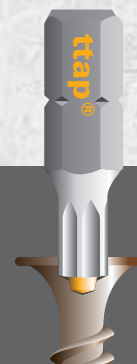

Die selbstbohrenden DeckWise®-schrauben für terrassendielen eignen sich für hartholz wie Ipe, Cumaru, Tigerwood, Garapa und Massaranduba.



## TORNILLOS AUTOPERFORADORES PARA TARIMAS

### No requieren perforación previa.

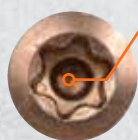

**ttap**® cabeza de tornillo en estrella T15 para un menor deslizamiento.

Cabeza tratada térmicamente para lograr una mayor resistencia.

Rosca dentada para eliminar el serrín.

Punta de cuatro lados para autoperforar.

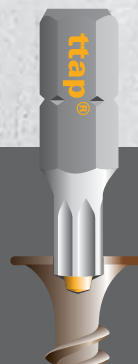

Los tornillos autoperforadores para tarimas DeckWise® pueden penetrar maderas duras como: Ipé, Cumaru, Tigerwood, Garapa o Massaranduba.



## ZELFBORENDE DEKSCHROEVEN

### Vorboren niet nodig.



**ttap**® T15 Torx-schroefkop voor meer grip.

Hittebehandeld voor extra gehardheid.

Getande zaagdraden verwijderen zaagsel.

Vierzijdige, zelfborende punt.



Zelfborende dekschroeven van DeckWise® dringen door in hardhoutsoorten als Ipé, Cumaru, Gonçalo alves, Garapa en Massaranduba.

# COLOUR-MATCH COMPOSITE SCREWS

Call us or your local DeckWise® dealer today to discuss how these screws are the wise choice – the DeckWise® choice.



Grey



Brown



Sand



T20 drive delivers plenty of torque without stripping out the heads.

Head designed to eliminate mushrooming or marring of deck surfaces.

These flutes grab the board and hold it tight to the joist.

These threads compress dust deep in the hole, further helping to reduce mushrooming.

These threads grab the joist to hold the board tight to the joist.

Sharp Type 17 auger point cuts fast and clean without splintering or splitting.







## VIS POUR COMPOSITES

Les embouts T20 offrent une puissance élevée sans endommager les têtes.

Les têtes sont conçues pour éliminer toute expansion ou marque sur la surface du platelage.

Ces cannelures agrippent la latte et la maintiennent fermement contre la solive.

Ces filetages compressent profondément la sciure dans les trous afin de réduire encore plus les risques d'expansion.

Ces filetages agrippent la solive afin que la latte soit solidement maintenue contre celle-ci.

Les pointes de foreuse pointues de type 17 forent rapidement et proprement sans que les lattes ne se fendent ou ne se fissurent.

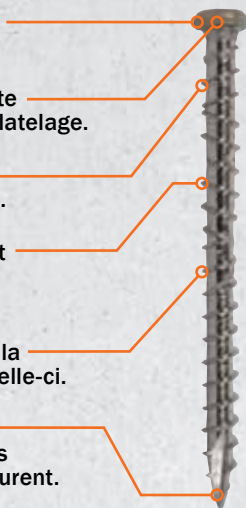

Gris composite

Marron bois dur

Sable

Contactez DeckWise® ou votre revendeur local dès aujourd'hui afin de savoir pourquoi ces vis constituent un bon choix - le choix DeckWise®.



## VERBUNDSCHRAUBEN

T20-Kopf bietet reichlich Drehmoment ohne Beschädigung der Köpfe.

Spezieller Schraubenkopf damit das Holz nicht nach oben gedrückt oder beschädigt werden.

Diese Gewindeflanken beißen sich in die Terrassendielen und pressen sie fest auf die Lattung.

Diese Gewinde komprimieren Bohrstaub im Loch und tragen so dazu bei, dass das Holz nicht nach oben gedrückt wird.

Diese Gewinde beißen sich in die Lattung, um die Terrassendielen fest zu montieren.

Scharfe Schneidspitze vom Typ 17 schneidet schnell und sauber ohne dass das Holz splittert oder bricht.



Kompositgrau

Hartholzbraun

Sand

Rufen Sie noch heute uns oder Ihren lokalen DeckWise®-Händler an, um zu besprechen, wieso diese Schrauben eine gute Wahl sind - die DeckWise®-Wahl.



## TORNILLOS COMPUESTOS

El tornillo T20 ofrece una torsión suficiente sin que se desprenda la cabeza.

La cabeza está diseñada para eliminar la formación de hongos o el deterioro de la superficie de la tarima.

Estas ranuras fijan la tabla y la sujetan con firmeza a la viga.

Estas roscas reducen el serrín en lo profundo del orificio y ayudan a reducir la formación de hongos.

Estas ranuras fijan la viga para sujetar la tabla con firmeza a esta.

La punta del taladro Sharp tipo 17 corta de manera rápida y perfecta sin formar astillas ni hendidas.



Gris compuesto

Marrón oscuro de tono madera noble

Arena

Póngase en contacto con nosotros o con su distribuidor local de DeckWise® y descubra por qué estos tornillos son la opción más inteligente - la opción DeckWise®.



## COMPOSIETSCHROEVEN

T20-schroevendraaiers leveren een groot draaimoment zonder de koppen te beschadigen.

Kop ontworpen om uitstulpingen en beschadigingen aan het dekoppervlak te voorkomen.

Deze groeven grijpen de plank vast en houden die strak tegen de balk.

Deze schroefdraden comprimeren stof diep in het gat, wat uitstulpingen verder helpt te voorkomen.

Deze schroefdraden grijpen de balk en houden de plank strak tegen de balk.

Scherpe boorpunt type 17 snijdt snel en schoon zonder splinters of scheuren.



Composietgrijs

Hardhoutbruin

Zand

Bel ons of uw lokale DeckWise®-dealer vandaag nog op om te horen waarom deze schroeven een goede keuze zijn - de DeckWise®-keuze.

# DECK TILE & CONNECTOR SYSTEMS



**IPE ANTI-SLIP**



**IPE SMOOTH**



**TIGERWOOD**



**CUMARU**

The DeckWise® Deck Tile System gives contractors, homeowners, and even renters a quick and easy way to renovate their outdoor living space. The DeckWise® Deck Tile System can be tailored to your specific needs.



**1 PREP**



**2 PLACE**



**3 REPEAT**

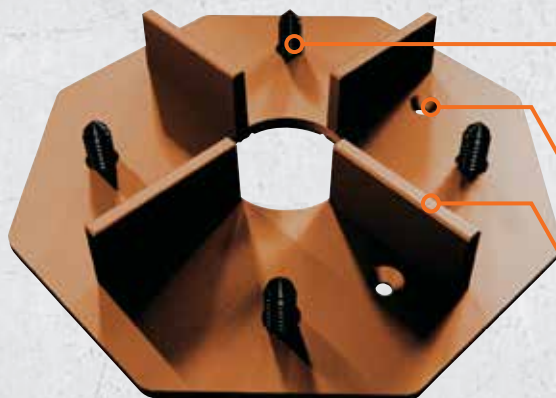

Patented; D665,657



Shadowline Black



Hardwood Brown

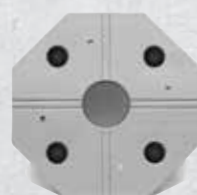

Composite Grey

Corner pins secure tile placement.

Elevates the deck tile from the wet subsurface to help prevent wood rot.

Chemical & UV resistant polyethylene.

Pre-drilled countersunk holes for easy fastening into a concrete slab or existing wooden deck.

Preset gap spacing for an even looking surface.

Can be divided into halves or quarters easily with hand tools using the pre-molded score lines.

Center drain hole provides improved drainage for water runoff to prevent pooling in the corners.

Matte texture provides better appearance between gaps.



## CONNECTEUR DE DALLE DE PLATELAGE

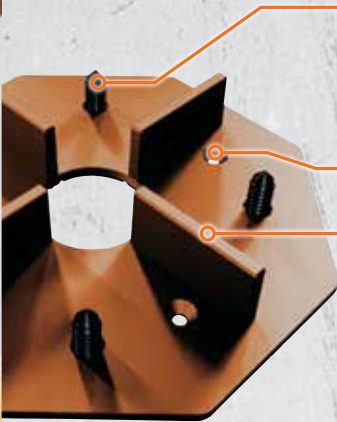

- Les goupilles d'angle assurent le placement des plaques.
- Écarte les plaques du platelage de l'humidité présente sous la surface afin de prévenir la pourriture du bois.
- Polyéthylène résistant aux UV et aux produits chimiques.
- Trous fraisés pré-perçés pour une fixation facile sur une dalle en béton ou un platelage en bois existant.
- Entretoise d'espacement pré-réglées pour une surface au look régulier.
- Peut facilement être divisé en deux ou quatre avec de l'outillage à main en utilisant les lignes de marquage pré-moulées.
- Le trou de drainage central permet une évacuation améliorée de l'eau afin de prévenir les accumulations dans les coins.
- La texture mat offre une meilleure apparence entre les espaces.

Patented; D665,657

Le système de plaque DeckWise® offre aux sous-traitants, propriétaires et même aux locataires une manière rapide et facile de rénover leur espace de vie extérieur.



## VERBINDER FÜR HOLZFLIESEN

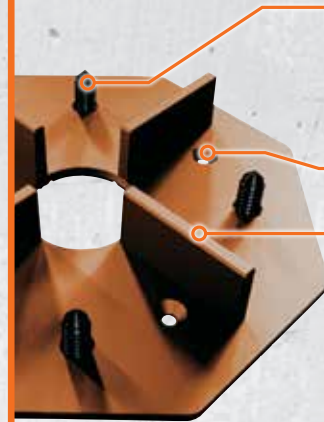

- Eckstift stellen die Ausrichtung der Holzfliesen sicher.
- Sorgt für einen Abstand zwischen der Holzfliese und dem feuchten Untergrund, um Holzfäulnis vorzubeugen.
- UV- und chemikalienbeständiges Polyethylen.
- Vorgebohrte angesenkte Löcher für einfache Montage in Beton oder einer bestehenden Holzterrasse.
- Festgelegte Fugenbreite für eine gleichmäßige Oberfläche.
- Kann durch die Prägungen einfach mit Handwerkzeugen halbiert oder gevierteilt werden.
- Das Abflussloch in der Mitte verbessert die Abführung von Wasser, um Ansammlung in den Ecken zu vermeiden.
- Die matte Oberfläche sieht zwischen den Fugen besser aus.

Patented; D665,657

The DeckWise® Deck Tile System gibt Bauunternehmern, Hausbesitzern und selbst Mietern eine schnelle und einfache Methode, um den Außenbereich zu renovieren.



## CONECTOR DE BALDOSA DE LA TARIMA

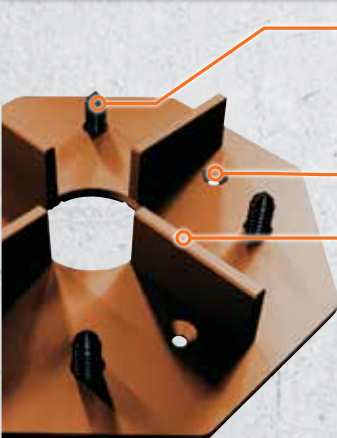

- Clavijas en las esquinas aseguran la ubicación de las baldosas.
- Elevan las baldosas de las tarimas ante la humedad subsuperficie para ayudar a prevenir el deterioro de la madera.
- Polietileno resistente a los rayos UV y los productos químicos.
- Agujeros avellanados pre-taladrados para fácil fijación sobre una losa de hormigón o una tarima de madera existente.
- Espaciamiento pre-establecido de las separaciones para una superficie de apariencia uniforme.
- Puede dividirse fácilmente en mitades o cuartos con instrumentos manuales usando líneas de marcado pre-diseñadas.
- Los agujeros centrales de drenaje proporcionan un drenaje mejorado para los escurrimientos de agua con el fin de prevenir la acumulación en las esquinas.
- La textura mate le da una mejor apariencia entre las separaciones.

Patented; D665,657

El sistema de baldosas para tarima de DeckWise® permite que los contratistas, propietarios e incluso arrendatarios renueven de manera rápida y sencilla sus espacios al aire libre.



## DEK TEGEL CONNECTOR

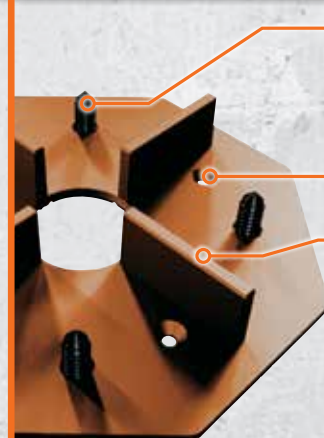

- Hoek pennen houden de tegels op hun plaats.
- Tilt de dek tegel op van de natte ondergrond om houtrot te voorkomen.
- Chemie en UV-bestendig polyethyleen.
- Vorgeboorde verzonken gaten voor eenvoudige bevestiging in een betonplaat of bestaand houten dek.
- Vooraf ingestelde afstand voor een effen uitzien oppervlak.
- Kan gemakkelijk worden onderverdeeld in helften of kwarten met handgereedschap met behulp van de gevormde lijnen.
- Een afvoerputje in het midden zorgt voor verbeterde waterafvoer en voorkomt water opeenhoping in de hoeken.
- De matte textuur zorgt voor een betere uitstraling tussen de leemten.

Patented; D665,657

Het DeckWise® Deck tegel systeem biedt ondernemers, huiseigenaren en zelfs huurders een snelle en eenvoudige manier hun outdoor living space te renoveren.



# HARDWOOD PLUGS

## COMPLETE PLUG SYSTEMS



### HARDWOOD PLUGS

SMOOTH



SIZE

9,5 mm  
(3/8")



CUMARU



TIGERWOOD



IPE



MASSARANDUBA



100

350

1050 & 1750

### EXTREME PLUGS™

RIBBED



SIZE

9,5 mm  
(3/8")



CUMARU



TIGERWOOD



IPE



GARAPA



MASSARANDUBA



10mm



12mm



Patent pending

Custom sizes available for our  
Hardwood Plugs and Extreme Plugs™.

Ask an associate for details,  
pricing, and minimum quantities.



### Master Plug Kit

- 350 or 1,050 Hardwood Plugs (choose from Ipe, Cumaru, Tigerwood, & Massaranduba. Garapa only available in Extreme Plugs™.)
- 350 or 1,050 DeckWise® 50,80 mm (#8x2") Stainless Steel Screws
- 1 complete Drill & Drive™ kit
- 118,3 ml (4 oz) bottle of Gorilla Glue®



## BOUCHONS POUR BOIS DUR ET SYSTÈMES DE BOUCHAGE COMPLETS

**BOUCHONS POUR BOIS DUR**  
Lisse



**EXTREME PLUGS™**  
Nervuré



Patent pending

### Kit de bouchon principal

- 350 or 1,050 Bouchons pour bois dur
- 350 or 1,050 DeckWise® 50,80 mm (#8x2")  
Vis en inox pour platelage
- 1 Drill & Drive™ kit  
(Outil de platelage 3 en 1)
- 118,3 ml (4 oz) Gorilla Glue®



Tailles standard disponibles pour notre hardwood et Extreme Plugs™. Demandez à un associé pour plus de renseignements, les prix et les quantités minimales.



## HARTHOLZ-STOPFEN UND STOPFEN-KOMPLETTSYSTEME

**HARTHOLZ-STOPFEN**  
Glatt



**EXTREME PLUGS™**  
Gerillt



Patent pending

### Master-Stopfen-Set

- 350 or 1,050 Hartholz-stopfen
- 350 or 1,050 DeckWise® 50,80 mm (#8x2")  
Edelstahlschrauben für terrassendielen
- 1 Drill & Drive™ kit  
(3-in-1 werkzeug für terrassendielen)
- 118,3 ml (4 oz) Gorilla Glue®



Für unser hartholz-stopfen und Extreme Plugs™ sind kundenspezifische größen erhältlich. Bitte fragen sie einen partner nach einzelheiten, preisen und mindestbestellmenge.



## ENCHUFES DE MADERA MACIZA & SISTEMAS COMPLETOS DE ENCHUFE

**ENCHUFES DE MADERA MACIZA**  
Suave



**EXTREME PLUGS™**  
Nervado



Patent pending

### Kit de enchufes master

- 350 or 1,050 Enchufes de madera maciza
- 350 or 1,050 DeckWise® 50,80 mm (#8x2")  
Tornillos de acero inoxidable para la tarima
- 1 Drill & Drive™ kit  
(Herramienta para entarimado 3 en 1)
- 118,3 ml (4 oz) Gorilla Glue®



Tamaños personalizados disponibles para nuestros enchufes extremos y de Extreme Plugs™. Pregunte a un asociado para más detalles, precios y cantidades mínimas.



## HARDHOUT PLUGGEN & COMPLETE PLUG SYSTEMEN

**HARDHOUT PLUGGEN**  
Glad



**EXTREME PLUGS™**  
Geribbeld



Patent pending

### Hoofdset Pluggen

- 350 or 1,050 Hardhout pluggen
- 350 or 1,050 DeckWise® 50,80 mm (#8x2")  
Roestvrij stalen dek schroeven
- 1 Drill & Drive™ kit  
(3-in1 dek gereedschap)
- 118,3 ml (4 oz) Gorilla Glue®



Aangepaste formaten beschikbaar voor onze hardhout en Extreme Plugs™. Vraag een medewerker voor meer informatie, prijzen en minimale hoeveelheden.

# DRILL&DRIVE™

3-IN-1  
DECKING TOOL



**DRILL**



**FLIP**



**DRIVE**

Use to countersink screws or for drilling plug holes with pilot holes all in one step.

## EVERY DRILL&DRIVE™ KIT INCLUDES:

- 1 Quick Change Locking Collar
- 2 3,175mm (1/8") High-speed Drill Bit & 9,525mm (3/8") Countersink Tool with T15 Star Drive Tip
- 3 4 5 3,175mm (1/8") Drill Bit & 9,525mm (3/8") Countersink
- 6 On-board Hex Key
- 7 8 9 10 T15 Star Drive Tip



Replacement tips	R1 Square Drive Tip	T10 Star Drive Tip	T15 Star Drive Tip
Replacement bits	3,175 mm (1/8") Drill Bit & 9,525 mm (3/8") Countersink	2,778 mm (7/64") Drill Bit & 7,938 mm (5/16") Countersink	3,175 mm (1/8") Drill Bit & 2,778 mm (7/64") Drill Bit

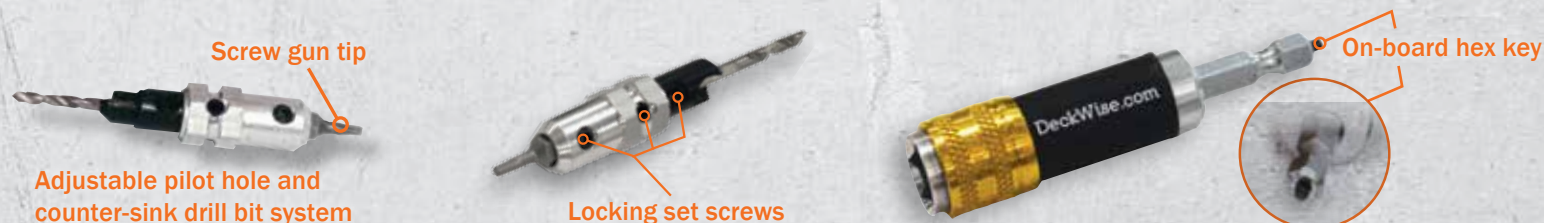



## OUTIL DE PLATELAGE 3 EN 1

### TOUS LES **DRILL&DRIVE™** KITS COMPRENNENT:

- 1 Collier de serrage à changement rapide.
- 2 Foret haute vitesse de 3,175 mm (1/8") et outil de fraisage de 9,525 mm (3/8") avec embout étoile T15.
- 3 4 5 Foret de 3,175 mm (1/8") et fraise de 9,525 mm (3/8").
- 6 À bord clé hexagonale.
- 7 8 9 10 Embout étoile T15.

Embouts de remplacement	Embout carré R1	Embout étoile T10	Embout étoile T15
Forets de remplacement	Foret de 3,175 mm (1/8") et Fraise de 9,525 mm (3/8")	Foret de 2,778 mm (7/64") et Fraise de 7,938 mm (5/16")	Foret de 3,175 mm (1/8") Foret de 2,778 mm (7/64")

Utilisez pour fraiser les vis ou pour percer les trous de bouchons à l'aide du trou pilote, le tout en une étape.



## 3-IN-1 WERKZEUG FÜR TERRASSENDIELEN

### JEDER **DRILL&DRIVE™** SET ENTHÄLT:

- 1 Schnellwechselkopf.
- 2 3,175 mm (1/8") hochgeschwindigkeits-schrauberbit und 9,525 mm (3/8") versenkbohrer mit T15 Torx-schrauberbit.
- 3 4 5 3,175 mm (1/8") schrauberbit und 9,525 mm (3/8") versenkbohrer.
- 6 Sechskantschlüssel.
- 7 8 9 10 T15 Torx-schrauberbit.

Ersatz-Bits	R1 Vierkant-schrauberbit	T10 Torx-schrauberbit	T15 Torx-schrauberbit
Ersatz-Bits	3,175 mm (1/8") Schrauberbit und 9,525 mm (3/8") Senkkopf	2,778 mm (7/64") Schrauberbit und 7,938 mm (5/16") Senkkopf	3,175 mm (1/8") Schrauberbit 2,778 mm (7/64") Schrauberbit

Zum vorbohren, ansenken oder zum bohren von löchern für die stopfen verwenden - alles in einem schritt.



## HERRAMIENTA PARA ENTARIMADO 3 EN 1

### TODOS LOS **DRILL&DRIVE™** KITS INCLUYEN:

- 1 Collarín bloqueador de cambio rápido.
- 2 Broca de alta velocidad 3,175 mm (1/8") y herramienta avellanadora 9,525 mm (3/8") punta de estrella T15.
- 3 4 5 Broca 3,175 mm (1/8") y avellanador 9,525 mm (3/8").
- 6 A bordo Llave hexagonal.
- 7 8 9 10 Punta de estrella T15.

Puntas de repuesto	Punta cuadrada R1	Punta de estrella T10	Punta de estrella T15
Brocas de repuesto	Broca 3,175 mm (1/8") y Avellanador 9,525 mm (3/8")	Broca 2,778 mm (7/64") y Avellanador 7,938 mm (5/16")	Broca 3,175 mm (1/8") Broca 2,778 mm (7/64")

Para tornillos avellanados o para taladrar agujeros de enchufe con agujeros piloto, todo en un paso.



## 3-IN1 DEK GEREEDSCHAP

### ELKE **DRILL&DRIVE™** KIT BEVAT:

- 1 Snel te verwisselen borgkraag.
- 2 3,175 mm (1/8") hoge snelheid boortop en 9,525 mm (3/8") verzonken schroeven gereedschap met T15 ster station tip.
- 3 4 5 3,175 mm (1/8") Boor en 9,525 mm (3/8") verzinkboor.
- 6 Inbussleutel.
- 7 8 9 10 T15 Ster boorkop.

vervangingsstips	R1 Vierkante boorkop	T10 Ster boorkop	T15 Ster boorkop
Vervangingstukken	3,175 mm (1/8") Boorkop en 9,525 mm (3/8") Verzinkboor	2,778 mm (7/64") Boorkop en 7,938 mm (5/16") Verzinkboor	3,175 mm (1/8") Boorkop 2,778 mm (7/64") Boorkop

Gebruik voor verzonken schroeven of voor het boren van voorboorgaten, alles in een moeite door.

# HARDWOOD WRENCH™

## THE ULTIMATE DECK BOARD STRAIGHTENING TOOL

**1 + 10 + 500** KG = **THE ULTIMATE**  
 TOOL CONFIGURATIONS BENDING FORCE DECK BOARD STRAIGHTENER



Adjustable stainless steel joist pins for use on up to 88,90 mm (3.5") joists

Hard-anodized aircraft grade aluminum

Stainless steel multi-position handle

Knurled stainless steel joist pins for increased gripping.



Solid hardwood handle

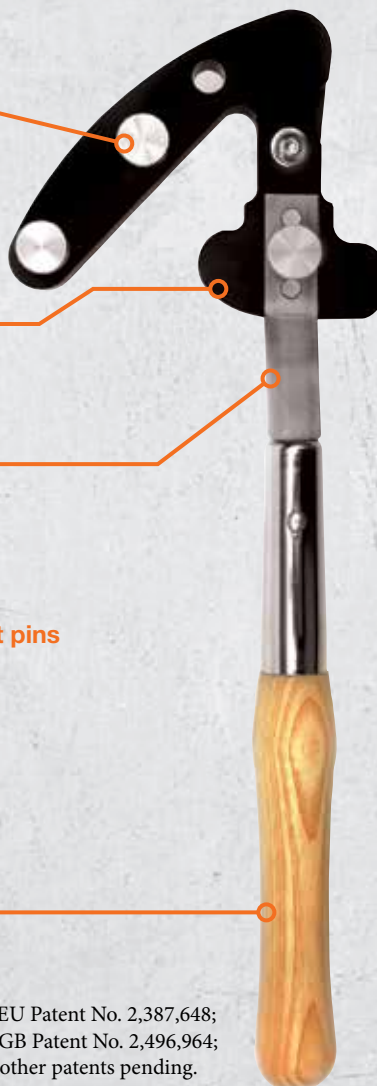

Patented; U.S. Patent No. D623,913; EU Patent No. 2,387,648; WIPO Patent No. WO2010/090812; GB Patent No. 2,496,964; DE Patent No. 202010001036.5; and other patents pending.

Place the **Hardwood Wrench™** on the joist.



Rotate the handle to straighten the boards.



Cam locks in place holding boards straight while fasteners are installed.





## OUTILS DE REDRESSEMENT DE LATTES DE PLATELAGE

Patented; U.S. Patent No. D623,913; EU Patent No. 2,387,648; WIPO Patent No. WO2010/090812; GB Patent No. 2,496,964; DE Patent No. 202010001036.5; and other patents pending.

Positionnez le **Hardwood Wrench™** sur la solive.



Tournez la poignée afin d'aligner les lattes.



Came de verrouillage en place, celle-ci maintient les lattes en place pendant que les fixations sont installées.

Inox goupilles de solives réglables pour utilisation sur des solives jusqu'à 88,90 mm (3.5")

Aluminium dur anodisé de qualité aéronautique

Inox poignée multi-position

Inox goupilles pour solives pour préhension accrue.

Bois dur massif poignée



## DER ULTIMATIVE BRETTTRICHTER

Patented; U.S. Patent No. D623,913; EU Patent No. 2,387,648; WIPO Patent No. WO2010/090812; GB Patent No. 2,496,964; DE Patent No. 202010001036.5; and other patents pending.

Setzen sie die **Hardwood Wrench™** auf den balken.



Drehen sie den griff, um die dielen gerade zu ziehen.



Der exzenter rastet ein und hält die dielen in position, während die befestiger montiert werden.

Edelstahl einstellbare balkenstifte zur benutzung für balken bis 88,90 mm (3.5")

Harteloxiertes flugzeug-aluminium

Edelstahl multi-positions-griff

Edekstahl stifte für erhöhte greif.

Griff aus solidem hartholz



**1+10+500** KG = **LE REDRESSEUR ULTIME DE LATTES**  
OUTIL CONFIGURATION FORCE DE FLEXION

**1+10+500** KG = **DER ULTIMATIVE BRETTTRICHTER**  
WERKZEUG KONFIGURATIONEN BIEGEKRAFT



## HERRAMIENTA PARA ENDEREZAR TABLAS DE LA TARIMA

Patented; U.S. Patent No. D623,913; EU Patent No. 2,387,648; WIPO Patent No. WO2010/090812; GB Patent No. 2,496,964; DE Patent No. 202010001036.5; and other patents pending.

Posicione el **Hardwood Wrench™** sobre la viga.



Mueva el mango para enderezar las tablas.



Las cerraduras en posición sosteniendo las tablas rectamente mientras se instalan los sujetadores.

Acero inoxidable clavijas de vigas ajustables para su uso en hasta bigas de 88,90 mm (3.5")

Aluminio aeronáutico anodizado duro

Acero inoxidable mango multi-posición

Acero inoxidable clavijas de vigas para el aumento de agarre.

Madera maciza sólida mango



## TANG OM HARDHOUT MEE TE RECHT TE BUIGEN

Patented; U.S. Patent No. D623,913; EU Patent No. 2,387,648; WIPO Patent No. WO2010/090812; GB Patent No. 2,496,964; DE Patent No. 202010001036.5; and other patents pending.

Plaats de **Hardwood Wrench™** op de dwarspen.



Draai aan de hendel om de planken recht te buigen.



Klemmen houden de planken op hun plaats terwijl de bevestigingsmiddelen worden geïnstalleerd.

Roestvrij staal verstelbare dwarspennen voor gebruik bij vloerbalken van maximaal 88,90 mm (3.5")

Hard geanodiseerd aluminium van luchtvaart kwaliteit

Roestvrij staal verstelbaarhandvat

Roestvrij staal dwarspennen voor meer grip.

Massiefhardhouten handvat



**1+10+500** KG = **EL ENDEREZADOR DE TABLAS PARA TARIMAS DEFINITIVO**  
HERRAMIENTA CONFIGURACIONES FUERZA DE CURVATURA

**1+10+500** KG = **DE ULTIEME DEKPLANKRICHTER**  
GEREEDSCHAP CONFIGURATIES BUIGKRACHT

# WISE GUIDES

## BOARD GAP SPACERS



### Board Gap Spacers



	3,125 mm (1/8")	3,97 mm (5/32")	5,16 mm (13/64")	6,35 mm (1/4")	7,94 mm (5/16")
6 PACK : 6 OF ANY 1 SIZE	✓	✓	✓	✓	✓
20 PACK : 20 OF ANY 1 SIZE	✓	✓	✓	✓	✓
20 PACK : 4 OF EACH SIZE	✓	✓	✓	✓	✓



**6 PACK**  
(6 Of Any 1 Size)



**20 PACK**

The special blade design of DeckWise® board gap spacers prevents denting and marring of hardwood or composite boards that are pressed together during installation. Moving laterally in between boards is a breeze thanks to the spacers unique handle.

Because attention to detail is what separates the amateurs from the professionals.



## ENTRETOISES DE LATTES DE PLATELAGE

3,125mm  
(1/8")



3,97mm  
(5/32")



5,16mm  
(13/64")



6,35mm  
(1/4")



7,94mm  
(5/16")



6 pièces



20 pièces  
4 de chaque taille

Parce que l'attention aux détails est ce qui différencie sépare les amateurs des professionnels.



## ABSTANDHALTER FÜR TERRASSENDIELEN

3,125mm  
(1/8")



3,97mm  
(5/32")



5,16mm  
(13/64")



6,35mm  
(1/4")



7,94mm  
(5/16")



6 er-packung



20 er-packung  
4 von jeder grösse

Weil die liebe zum detail den unterschied zwischen amateuren und profis ausmacht.



## SEPARADORES DE TABLAS DE TARIMA

3,125mm  
(1/8")



3,97mm  
(5/32")



5,16mm  
(13/64")



6,35mm  
(1/4")



7,94mm  
(5/16")



Paquete de 6



Paquete de 20  
4 de cada tamaño

Porque prestar atención a los detalles es lo que distingue a los principiantes de los profesionales.



## DEK BOORD AFSTANDSHOUDERS

3,125mm  
(1/8")



3,97mm  
(5/32")



5,16mm  
(13/64")



6,35mm  
(1/4")



7,94mm  
(5/16")



6 Stuks



20 Stuks. 4 van  
elke grootte

Omdat aandachtvoor details is wat de amateurs scheidt van de professionals.

# DECK BUILDING ACCESSORIES



## Drill bits & tips

3,175mm (1/8") high speed drill bit



Dependable. Tough. Long-lasting.  
These high speed drill bits are ideal for  
pre-drilling dense hardwood decking.



R1 Square Drive Tip



T10 Star Drive Tip



T15 Star Drive Tip



**ttap** T15 Star Drive Tip

Other sizes and lengths available.

## Adhesives



**GORILLA GLUE®**

**1,07L**  
(36 oz)

**118,3ml**  
(4 oz)



ACCESSOIRES

Forets et embouts



Foret haute vitesse de 3,175 mm (1/8")



Embout carré R1



Embout étoile T10

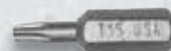

Embout étoile T15



**ttap**® Tête étoile T15

D'autres tailles et longueurs sont.

Adhésifs



GORILLA  
GLUE®

1,07L  
(36 oz)

118,3ml  
(4 oz)



ZUBEHÖR

Bohrer und schrauberbits



3,175 mm (1/8")  
Hochgeschwindigkeits-schrauberbit



R1 Vierkant-schrauberbit



T10 Torx-schrauberbit



T15 Torx-schrauberbit



**ttap**®  
T15 Torx-schraubekopf

Andere größen und längen erhältlich.

Kleber



GORILLA  
GLUE®

1,07L  
(36 oz)

118,3ml  
(4 oz)



ACCESORIOS

Brocas y puntas



brocas de alta velocidad 3,175 mm (1/8")



Punta cuadrada R1



Punta de estrella T10



Punta de estrella T15



**ttap**® Cabeza de tornillo  
en estrella T15

Están disponibles otros tamaños y longitudes.

Adhesivos



GORILLA  
GLUE®

1,07L  
(36 oz)

118,3ml  
(4 oz)



ACCESSOIRES

Boorkoppen und tips



Hoge snelheid boorkop 3,175 mm (1/8")



R1 Vierkante boorkop



T10 Ster boorkop



T15 Ster boorkop



**ttap**® T15 Torxschroefkop

Andere maten en lengtes verkrijgbaar.

Kleefmiddelen



GORILLA  
GLUE®



1,07L  
(36 oz)

118,3ml  
(4 oz)

# CONTRACTOR BUCKETS



**Page 8**

 OR
 
 OR
 

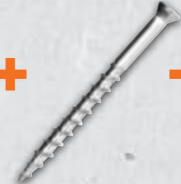

**DeckWise®**  
**Hidden Deck Fasteners**

**Page 12**





Stainless Steel Screws

**Page 26**

 OR
 

**Wise Guide**  
**Board Gap Spacers**

**Page 28**

 +
 

T15 Star Drive Tip  
 3,175 mm (1/8")  
 Drill Bit

The new Contractor Buckets from DeckWise® were made with contractors in mind. Containing enough clips, screws and accessories for even the biggest decking projects, you'll have everything you need to get the job done. DeckWise® Contractor Buckets are available in both 525 and 1050 quantity buckets.



525 Pieces Contractor Bucket	1050 Pieces Contractor Bucket
<b>525</b> Hidden Deck Fasteners	<b>1050</b> Hidden Deck Fasteners
<b>565</b> Stainless Steel Screws	<b>1130</b> Stainless Steel Screws
<b>6</b> Deck Board Spacers*	<b>6</b> Deck Board Spacers*
<b>3</b> T15 Star Drive Tips	<b>5</b> T15 Star Drive Tips
<b>3</b> 3,175 mm (1/8") High Speed Drill Bits	<b>5</b> 3,175 mm (1/8") High Speed Drill Bits

\*(Deck Board Spacers are Available in Extreme4™ and ExtremeKD™ Buckets Only)



## SEAUX POUR ENTREPRENEURS

Seau pour entrepreneur de <b>525 pièces</b>	Seau pour entrepreneur de <b>1050 pièces</b>
<b>525</b> Système de fixations invisibles	<b>1050</b> Système de fixations invisibles
<b>565</b> Vis en inox	<b>1130</b> Vis en inox
<b>6</b> Outils d'espacement pour platelages*	<b>6</b> Outils d'espacement pour platelages*
<b>3</b> Embouts étoile T15	<b>5</b> Embouts étoile T15
<b>3</b> Forets haute vitesse de 3,175 mm (1/8")	<b>5</b> Forets haute vitesse de 3,175 mm (1/8")

\*(Disponible dans les seaux **Extreme4™** et **ExtremeKD™** uniquement)

Les nouveaux seaux pour entrepreneurs de DeckWise® ont été fabriqués conformément aux besoins des entrepreneurs. Ils contiennent suffisamment d'attaches, de vis et d'accessoires afin que vous disposiez de tout ce qu'il faut pour réaliser les plus grands projets de platelages. Les seaux pour entrepreneurs de DeckWise® proposent des quantités de 525 et de 1050 au choix.



## AUFTRAGNEHMER BUCKET

Auftragnehmer Bucket <b>525 stücken</b>	Auftragnehmer Bucket <b>1050 stücken</b>
<b>525</b> Unsichtbare befestigung für holzverkleidungen	<b>1050</b> Unsichtbare befestigung für holzverkleidungen
<b>565</b> Edelstahlschrauben	<b>1130</b> Edelstahlschrauben
<b>6</b> Distanzstücke*	<b>6</b> Distanzstücke*
<b>3</b> T15 Torx-schrauberbits	<b>5</b> T15 Torx-schrauberbits
<b>3</b> 3,175 mm (1/8") Hochgeschwindigkeits-schrauberbit	<b>5</b> 3,175 mm (1/8") Hochgeschwindigkeits-schrauberbit

\*(Nur erhältlich in **Extreme4™** und **ExtremeKD™** - eimern)

Die neuen auftragnehmer bucket von DeckWise® wurden speziell für unternehmen entwickelt. Sie enthalten ausreichend clips, schrauben und zubehör für selbst die größten projekte, damit sie alles haben, um den auftrag zu erledigen. DeckWise® auftragnehmer bucket sind mit 525 und 1050 stück erhältlich.



## CUBETAS PARA CONTRATISTAS

Cubeta de contratista de <b>525 piezas</b>	Cubeta de contratista de <b>1050 piezas</b>
<b>525</b> Sujetadores ocultos para tarimas	<b>1050</b> Sujetadores ocultos para tarimas
<b>565</b> Tornillos de acero inoxidable	<b>1130</b> Tornillos de acero inoxidable
<b>6</b> Herramientas espaciadoras para tarimas*	<b>6</b> Herramientas espaciadoras para tarimas*
<b>3</b> Puntas de tornillo en estrella T15	<b>5</b> Puntas de tornillo en estrella T15
<b>3</b> Brocas de 3,175 mm (1/8") para taladro de alta velocidad	<b>5</b> Brocas de 3,175 mm (1/8") para taladro de alta velocidad

\*(Disponible solo con las cubetas **Extreme4™** y **ExtremeKD™**)

Las nuevas cubetas para contratistas de DeckWise® fueron fabricadas según las necesidades de los contratistas. Con suficientes abrazaderas, tornillos y accesorios hasta para los proyectos de entarimado más grandes, tendrá a su disposición todo lo que necesita para realizar su trabajo. Las cubetas para contratistas DeckWise® están disponibles en cubetas de 525 y 1050 elementos.



## AANNEEMEREMMERS

Aannemeremmers van <b>525 stukken</b>	Aannemeremmers van <b>1050 stukken</b>
<b>525</b> Verborgen dek bevestigings	<b>1050</b> Verborgen dek bevestigings
<b>565</b> Roestvrijstalen schroeven	<b>1130</b> Roestvrijstalen schroeven
<b>6</b> Afstandhouders*	<b>6</b> Afstandhouders*
<b>3</b> T15 Torxschroevendraaiers	<b>5</b> T15 Torxschroevendraaiers
<b>3</b> 3,175 mm (1/8") High-speed boorkoppen	<b>5</b> 3,175 mm (1/8") High-speed boorkoppen

\*(Alleen beschikbaar in **Extreme4™** en **ExtremeKD™** emmers)

De nieuwe aannemeremmers van DeckWise® zijn gemaakt voor aannemers. Ze bevatten genoeg clips, schroeven en accessoires voor zelfs de grootste dekprojecten, zodat je alles hebt wat je nodig hebt om de klus te klaren. Aannemeremmers van DeckWise® zijn beschikbaar in emmers met zowel 525 als 1050 stuks.



## Manufacturers of Hidden Deck Fasteners and Accessories



**Les fabricants de fixations et d'accessoires de pont cachés.**



**Hersteller von hidden deck befestigungen und zubehör.**



**Los fabricantes de sujetadores cubierta ocultos y accesorios.**



**Fabrikanten van hidden deck fasteners en accessoires.**

### North American Administration & Manufacturing Facility

DeckWise®  
The Ipe Clip® Fastener Company, LLC  
2111 58th Ave. East  
Bradenton, FL 34203

Telephone number: +1 941-896-9851  
Toll Free: +1 866-427-2547  
Fax number: +1 941-896-9858

### European Sales Office

Deckwise® International B.V.  
Nijverheidsweg Noord 60-2  
3812 PM Amersfoort  
The Netherlands

Telephone number: + 31 33 4691037  
Fax number: + 31 33 4480525

VAT number: NL8514.52.863.B.01.  
Chamber of Commerce number: 54820634

**DeckWise**.com  
International B.V.